

Tool Code	Hole Size	Sym bol	Hole Count

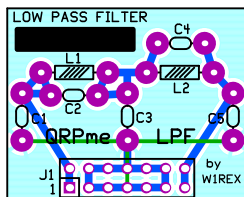

The band module board is symmetrical. For the Lil' Squall, rf input is on the right side pins 13+14. RF output is from left side pins 1+2.

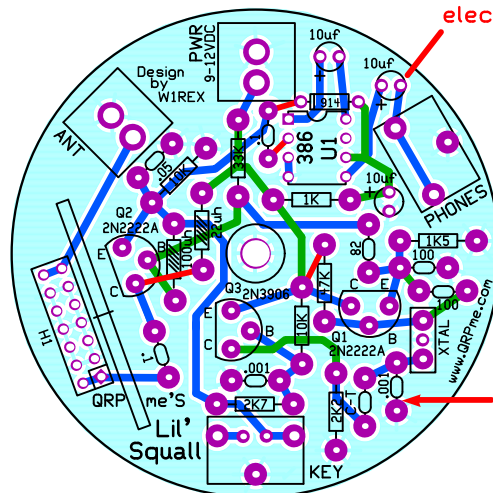

10uf pad closest to the edge of the board could short to the rim of the can. Use some electrical tape or similar item to insulate the pad

4 parts are unconnected on one end. When placing these parts on the board, don't clip off the excess lead marked in RED.. Bend the excess lead over to the pad indicated, cut to the required length and solder to the pads shown.

- 1: 47K resistor to the 10K resistor
- 2: .1uf cap to LM386 pin2
- 3: 914 diode to .1uf cap
- 4: 22uh choke to Q2 collector or use a zero ohm jumper supplied

C-T & .001 caps are reversed. solder the .001 @ C-T and the C-T cap socket pins in the .001 spot

Board type: FR4
Board thickness: .062"
Copper weight: 1oz
Layer count: 2

All dimensions are in inches.

Board should have blue solder mask over bare copper (SMOBC) with white silk screening on top.

View is from the top side of the board.

Lil' Squall Bill of Materials

- 1 - 2N3866 TRANSISTOR @Q2 (house marked)
- 1 - LM386 AUDIO AMPLIFIER
- 1 - 2N2222A TRANSISTOR @Q1
- 1 - 2N3906 TRANSISTOR @Q3
- 1 - 1N914 DIODE (or 1N4148 DIODE)
- 1 - 7030 & 7.0475 & 7.122 CRYSTALS
- 1 - 10 OHM RESISTOR
- 1 - 1K RESISTOR
- 1 - 1.5K RESISTOR
- 1 - 2.2K RESISTOR
- 1 - 2.7K RESISTOR
- 2 - 10K RESISTOR
- 1 - 33K RESISTOR
- 1 - 47K RESISTOR
- 1 - 22uh CHOKE
- 1 - 100uh CHOKE
- 2 - 82 pf CAPACITOR (1 = C-T)
- 2 - 100pf CAPACITOR
- 2 - .001uf CAPACITOR
- 1 - .05 (.047) CAPACITOR
- 3 - .1uf CAPACITORS
- 3 - 10uf ELECTROLYTIC CAPACITOR

- 1 - 2 SCREW TERMINAL BLOCK
- 1 - YELLOW RCA JACK
- 2 - STEREO JACKS
- 1 - 2x7x.1" FEMALE HEADER
- 2 - 8 pin SIP socket (IC pins)
- 1 - 8 pin DIP SOCKET
- 1 - 1x2x.1" MALE MOLEX HEADER

- 1 - 1/8" x 1.5" BOLT
- 1 - 1/8" x 32 NUT
- 1 - 211 TUNA CAN
- 1 - LIL' SQUALL PCB
- 1 - LABEL

Lil' Squall 40m Band Module

- 1 - LIL' SQUALL LPF PCB
- 1 - 47pf CAPACITOR @C4
- 1 - 150pf CAPACITOR @C2
- 2 - 330pf CAPACITOR @C1 & C5
- 1 - 680pf CAPACITOR @C3
- 1 - 1.2uh CHOKE @L2
- 1 - .82uh CHOKE @L1
- 1 - 2x7x.1" RIGHT ANGLE MALE HEADER

ModS

- 1 - 0 OHM JUMPER
- 2 - .1UF CAPS
- 1 - 1N5818 DIODE

Co:	QRPme
Title:	Lil' Squall Build Notes
Board:	Lil' Squall
Revision:	B
Drawn:	W1REX
Size:	A
Date:	03/20/2011
Sheet	1 of 1